

## Pelvic Floor Muscle Exercises for Women

### This leaflet is designed to help you:

1. Understand the function of the pelvic floor.
2. Understand why you need to exercise your pelvic floor.
3. Know how to do pelvic floor exercises.
4. Help the health of your bladder and bowel.

### What and where is the pelvic floor?

The pelvic floor is a bowl of muscles rather like a hammock which passes from the pubic bone at the front of the pelvis to the tail bone (coccyx) at the back. Its function is to support the pelvic organs and prevent leakage of urine/faeces from the bladder or bowel by keeping the outlets closed.

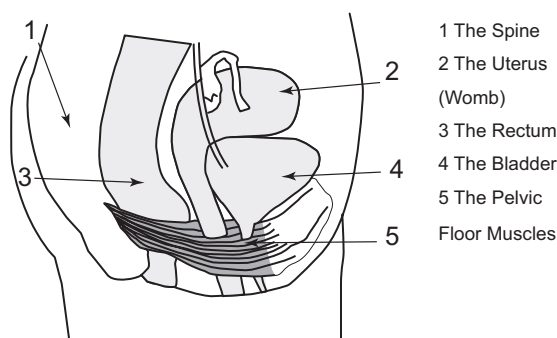

### Why do I need to exercise the pelvic floor?

Like other muscles of the body, the pelvic floor muscles need regular exercise to retain good muscle tone. If they are not exercised they may become stretched and weak and no longer work effectively. Symptoms of weakness could include:

- Urinary leakage when you cough, laugh, sneeze or even when you move to get out of a chair. This is known as stress urinary incontinence (SUI).
- A sudden feeling that you need to rush to the toilet (urgency) followed by urinary leakage. However, this can primarily be due to 'other factors' mentioned later in this leaflet.
- A prolapse which may be felt as general pelvic discomfort or as 'something coming down'.

This may also happen following childbirth or in later years following the menopause or after pelvic or abdominal surgery. If carried out correctly and regularly pelvic floor exercises will help to prevent and aid the correction of these symptoms.

### How to identify the pelvic floor

There are a variety of ways to identify your pelvic floor. This is important so that you know you are exercising the right muscles.

- Vaginal examination – feel inside your vagina with one or two fingers. See if you can squeeze them with your pelvic floor muscles.
- Imagine trying to hold onto wind when it is trying to escape from the back passage.
- Imagine trying to prevent a tampon from falling out of the vagina.
- Try to stop the flow of urine – the 'stop test'. Do this no more than once a week.

# How do I do pelvic floor exercises (PFEs)?

You can do these in any position, sitting in a chair, lying down or standing. However it is important to be relaxed when exercising and some people find it easier to start exercising lying down and progress to sitting and standing positions when they feel stronger.

There are two types of muscle fibre to be exercised and so you need to do both long squeezes and short quick squeezes. Plus it is also good to build the endurance and strength of the muscle.

## 1. Long hold squeeze for strength

- Breathe normally and relax. Try not to hold your breath.
- Tighten your pelvic floor muscles, hold for several seconds and then relax for several seconds.

Repeat this a few times.

- How long can you hold for? seconds
- How many times can you repeat that hold? repetitions

This is known as a set of exercises.

Repeat this set of exercises 3-4 times daily. You should try to increase the length of time you can hold by one second every 7 to 10 days. There is no need to hold for more than 10 seconds or to repeat more than 10 times.

## Physiotherapy reminder

**Try to ensure all you other muscles are relaxed, especially the buttocks and shoulders and breathe normally. It is normal to feel your lower tummy muscles contract when you tighten the pelvic floor.**

## 2. Short quick squeezes for speed

Tighten and release the pelvic floor muscles as quickly as you can at the end of each set of long squeezes. It should still be a powerful squeeze so

make sure you hold for at least one second and relax for one second.

As a general guide, aim for 10 short quick squeezes 3 to 4 times a day.

## 3. Exercises for endurance

Pull the muscles up to about half of their maximum squeeze. Try and hold this up to half a minute. Practice whilst you are out walking. You must be able to breathe normally and hold this gentle contraction.

## 4. Functional squeeze 'The Knack'

Try and remember to get into good habits and contract and hold the pelvic floor muscles tight before you cough or sneeze, this will improve control and leakage. It is easy to practice these short quick squeezes at intervals through the day to make sure the muscle fibres are exercised and in good condition to give enough bladder support on coughing and sneezing.

## Improving your pelvic floor muscles

It can take up to 6 months or even a year before significant improvement is made, don't be disheartened and don't give up.

Pelvic floor exercises should be a lifetime habit. You do not need to do a daily programme forever, just keep up with a 'maintenance regime' when your symptoms have resolved and your muscles feel strong.

You can do these exercises anytime, any place, anywhere.

## How will I know if my pelvic floor muscles are getting stronger?

- You may find it easier to slow down or stop the flow of urine mid-stream. Do not do this more than once a week.
- You may notice that you leak less urine when you cough, laugh or sneeze etc.
- Your specialist physiotherapist will also monitor your progress.

## Other factors which may help aid your pelvic floor recovery

- Try to lose weight if you need to.
- Avoid constipation – straining to have your bowels open stretches the pelvic floor muscle. It is important to avoid this with the right diet and fluid intake. Ask for help from your GP/ Nurse if necessary.
- Avoid heavy lifting and high impact exercise, as this puts a strain on the pelvic floor (PF).
- When you are trying to build strength in your PF try and avoid strong exercises for your abdominals and upper limb as this can increase the pressure on your pelvic floor.

## Other factors which help the bladder which are not necessarily caused by pelvic floor weakness

1. Caffeine present in tea, coffee and coke can irritate the bladder and caused bladder urinary leakage. Try and swap these drinks for water and drink approximately 4 pints of liquid daily.
2. Never cut down on fluid intake. However if you drink excessive quantities and are especially thirsty it would be worth mentioning this to your GP.
3. Don't empty the bladder too frequently just to avoid leaking, this will cause the bladder to reduce its comfortable capacity and ultimately make existing problems worse.
4. Your bladder should be able to hold about a pint by day and should not need emptying more than 2 hourly, although up to 4 hours should be possible. Teach your bladder to 'hold on'.

The Trust cannot accept any responsibility for the accuracy of the information given if the leaflet is not used by RD&E staff undertaking procedures at the RD&E hospitals.

© Royal Devon and Exeter NHS Foundation Trust

Designed by Graphics (Print & Design), RD&E